

DESIGNED	{designd}	TITLE 7Seg x2,TactSW x4
DRAWN	{drawn}	
CHECKED	{chekd}	
APPROVED	{approved}	
DATE	2002.11.12	Size A3 (2 / 8)
MODEL	EV-Stratix	DRAW No. (doc) REV
		SK-Electronics CO.,LTD. 2.4

3				
2				
1				
SYM	REVISION	DATE	REVISED	APPROVED

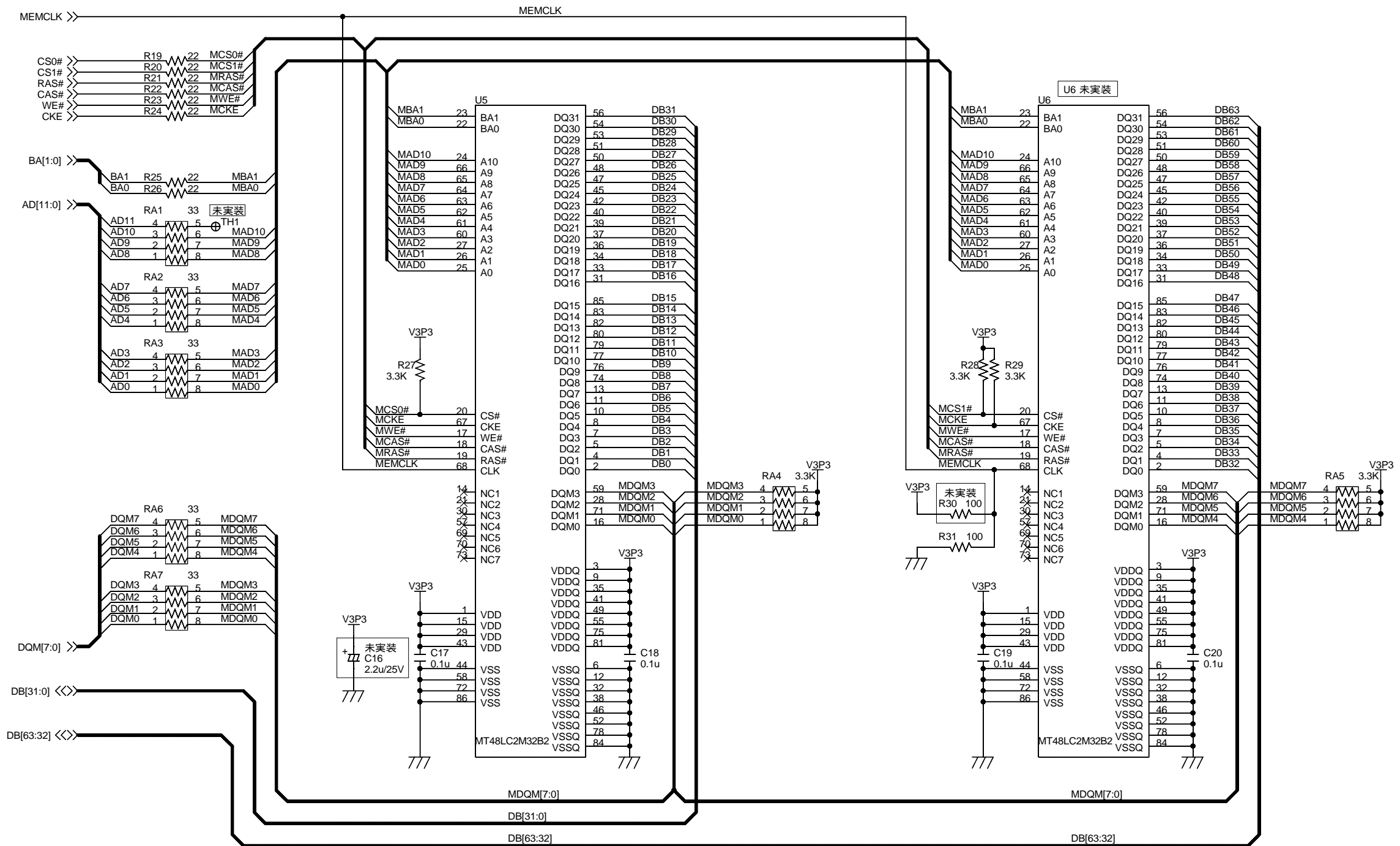

DESIGNED	{designd}	TITLE SDRAM 64Mbit
DRAWN	{drawn}	
CHECKED	{chekd}	
APPROVED	{approved}	
DATE	2002.11.27	Size A3 (3 / 8)
MODEL	EV-Stratix	DRAW No. (doc) REV
SK-Electronics CO.,LTD.		2.4

3				
2				
1				
SYM	REVISION	DATE	REVISED	APPROVED

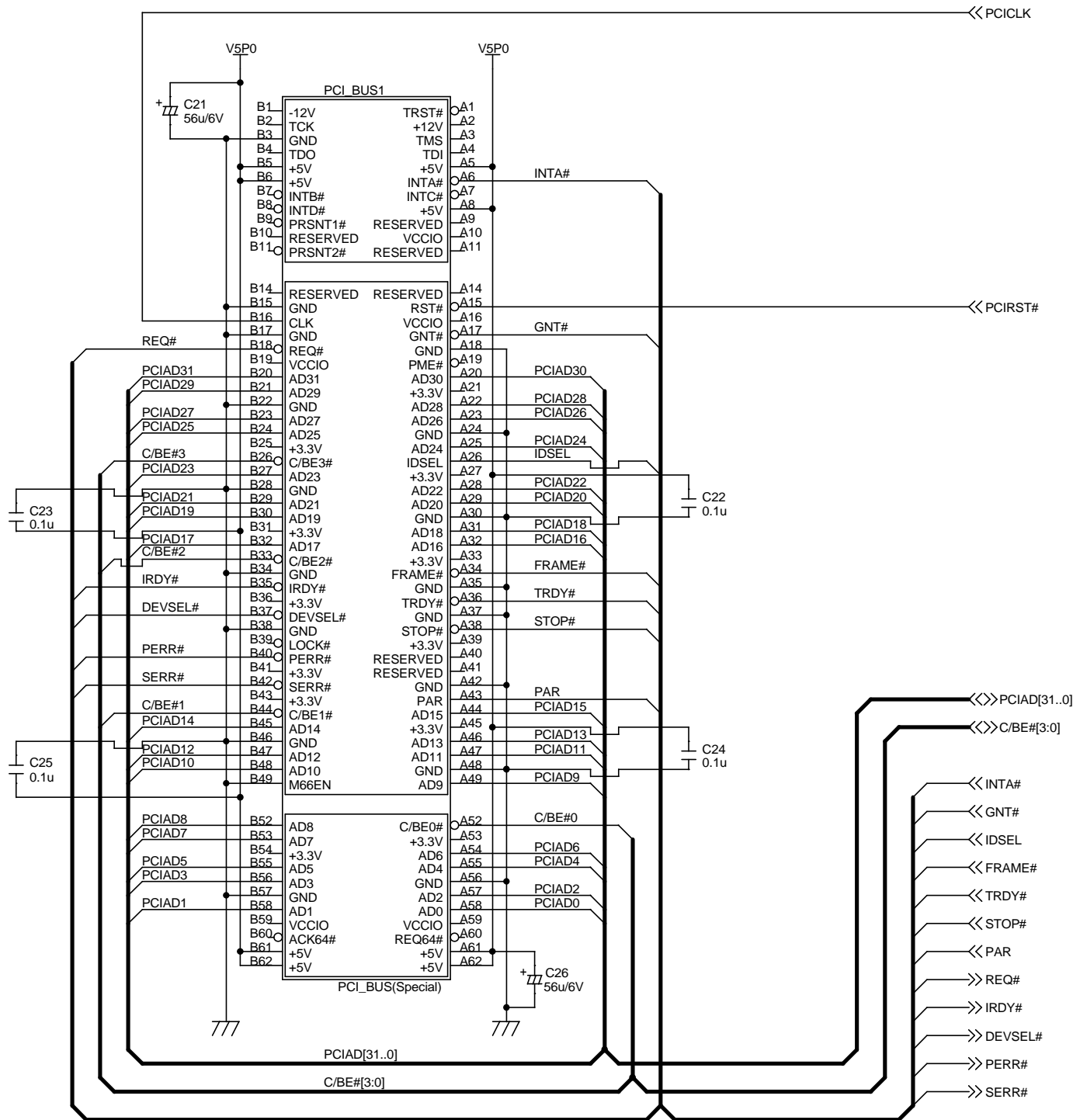

DESIGNED	{designd}	TITLE PCI-32 I/F
DRAWN	{drawn}	
CHECKED	{chekd}	
APPROVED	{approved}	Size A3
DATE	2002.11.27	(4 / 8)
MODEL	EV-Stratix	DRAW No. (doc)
REV		SK-Electronics CO.,LTD.
2.4		

3				
2				
1				
SYM	REVISION	DATE	REVISED	APPROVED

DEVICE1A

PCIAD8 A3 IO/DQ0T1(B4,V5B4)
PCIAD9 A4 IO/DQ0T0(B4,V5B4)
PCIAD11 A5 IO/DQ0T6(B4,V5B4)
SERR# A6 IO/DQ1T1(B4,V5B4)
DEVSEL# A7 IO/DQ1T4(B4,V5B4)
FRAME# A8 IO/DQ2T6(B4,V5B4)
PCIAD16 A9 IO/DQ2T7(B4,V5B4)
PCIAD20 A10 IO/DQ3T1(B4,V4B4)
PCIAD23 A11 IO/DQ3T4(B4,V4B4)
PCIAD29 A18 IO/DQ6T0(B3,V5B3)
REQ# A19 IO/DQ6T3(B3,V5B3)
INT# A20 IO/DQ7T1(B3,V4B3)
SW-IN3 A21 IO/DQ7T3(B3,V4B3)
RTS2 A22 IO/DQ8T1(B3,V4B3)
CTS1 A23 IO/DQ8T4(B3,V4B3)
TXD1 A24 IO/DQ9T0(B3,V4B3)
LED-DB5 A25 IO/DQ9T2(B3,V4B3)
LED-DB2 A26 IO/DQ9T6(B3,V4B3)
PCIAD7 B3 IO/DQ0T2(B4,V5B4)
C/BE#0 B4 IO/DQ0T4(B4,V5B4)
PCIAD12 B5 IO/DQ0T3(B4,V5B4)
PAR B6 IO/DQ1T2(B4,V5B4)
STOP# B7 IO/DQ1T5(B4,V5B4)
IRDY# B8 IO/DQ1T7(B4,V5B4)
PCIAD17 B9 IO/DQ2T4(B4,V5B4)
PCIAD19 B10 IO/DQ2T5(B4,V5B4)
PCIAD22 B11 IO/DQ3T3(B4,V4B4)
PCIAD28 B18 IO/DQ3T7(B4,V4B4)
PCIAD30 B19 IO/DQ6T4(B3,V5B3)
PCIIRST# B20 IO/DQ7T0(B3,V4B3)
SW-IN4 B21 IO/DQ7T4(B3,V4B3)
TXD2 B22 IO/DQ8T0(B3,V4B3)
RTS1 B23 IO/DQ8T7(B3,V4B3)
LED-DB4 B24 IO/DQ9T4(B3,V4B3)
LED-DB3 B25 IO/DQ9T5(B3,V4B3)
LED-DB0 B26 IO/DQ9T7(B3,V4B3)
PCIAD6 C4 IO/DQ0T5(B4,V5B4)
PCIAD10 C5 IO/DQ0T7(B4,V5B4)
C/BE#1 C6 IO/DQ1T6(B4,V5B4)
PERR# C7 IO/DQ1T7(B4,V5B4)
TRDY# C8 IO/DQ2T1(B4,V5B4)
C/BE#2 C9 IO/DQ2T2(B4,V5B4)
PCIAD18 C10 IO/DQ3T5(B4,V4B4)
PCIAD21 C11 IO/DQ3T5(B4,V4B4)
PCIAD27 C18 IO/DQ6T1(B3,V5B3)
PCIAD31 C19 IO/DQ6T5(B3,V5B3)
GNT# C20 IO/DQ7T2(B3,V4B3)
CTS2 C21 IO/DQ7T5(B3,V4B3)
RXD2 C22 IO/DQ8T2(B3,V4B3)
RXD1 C23 IO/DQ8T5(B3,V4B3)
LED-OE0 C24 IO/DQ9T3(B3,V4B3)
LED-DB1 C25 IO/DQ9T1(B3,V4B3)

EP1S10-FBGA780

DEVICE1B

D5 PCIAD3 EXDB55 L1 IO/DIFFIO_RX30n(B5,V4B5)
D6 PCIAD5 EXDB52 L2 IO/DIFFIO_RX30p(B5,V4B5)
D7 PCIAD13 EXDB53 L3 IO/DIFFIO_RX29n(B5,V4B5)
D8 PCIAD14 L4 IO/DIFFIO_RX29p(B5,V4B5)
D9 PCIAD15 EXDB3 L5 IO/DIFFIO_TX24p(B5,V3B5)
D10 C/BE#3 EXDB0 L6 IO/DIFFIO_TX24n(B5,V3B5)
D11 PCIAD24 EXDB1 L7 IO/DIFFIO_TX23p(B5,V3B5)
D18 PCIAD25 L8 IO/DIFFIO_TX23n(B5,V3B5)
D19 PCIAD26 L9 IO/DIFFIO_TX25p(B5,V3B5)
D20 SW-IN1 L10 IO/DIFFIO_TX25n(B5,V3B5)
D21 SW-IN2 L11 IO(B4,V5B4)
D22 LED-DB7 L12 IO(B3,V4B3)
D23 LED-OE1 L19 IO/DIFFIO_TX18n(B2,V4B2)
D24 LED-OE2 L20 IO/DIFFIO_TX10n(B1,V4B1)
E6 PCIAD1 L21 IO/DIFFIO_TX20n(B2,V4B2)
E8 PCIAD4 L22 IO/DIFFIO_TX20p(B2,V4B2)
E9 IDSEL L23 IO/DIFFIO_TX19p(B2,V4B2)
E19 RESET-SW L24 IO/DIFFIO_TX19n(B2,V4B2)
E21 LED-DB6 L25 IO/DIFFIO_RX14p(B2,V3B2)
E23 LED-OE3 L26 IO/DIFFIO_RX14n(B2,V3B2)
E23 LED-OE3 L27 IO/DIFFIO_RX13p(B2,V3B2)
E23 LED-OE3 L28 IO/DIFFIO_RX13n(B2,V3B2)
F8 PCIAD2 EXDB57 M2 IO/DIFFIO_RX32n(B5,V4B5)
F17 EXDB54 M3 IO/DIFFIO_RX31n(B5,V4B5)
G1 EXDB43 EXDB56 M4 IO/DIFFIO_RX31p(B5,V4B5)
G2 EXDB40 EXDB5 M5 IO/DIFFIO_RX27p(B5,V3B5)
G7 PCIAD0 EXDB2 M6 IO/DIFFIO_TX27n(B5,V3B5)
G11 M7 IO/DIFFIO_TX26p(B5,V3B5)
G27 EXDB37 M8 IO/DIFFIO_TX26n(B5,V3B5)
M9 IO/DIFFIO_TX4p(B1,V3B1)
G28 M10 IO/DIFFIO_TX4n(B1,V3B1)
H1 EXDB44 M11 IO(B4,V5B4)
H2 EXDB45 M18 IO(B3,V4B3)
H3 EXDB42 M19 IO/DIFFIO_TX15n(B2,V3B2)
H4 EXDB41 M20 IO/DIFFIO_TX15p(B2,V3B2)
H11 M21 IO/DIFFIO_TX17n(B2,V4B2)
H25 EXDB36 M22 IO/DIFFIO_TX17p(B2,V4B2)
H26 EXDB39 M25 IO/DIFFIO_RX12p(B2,V3B2)
H27 M26 IO/DIFFIO_RX12n(B2,V3B2)
H28 M27 IO/DIFFIO_RX11p(B2,V3B2)
J1 EXDB49 M25 IO/DIFFIO_RX12p(B2,V3B2)
J2 EXDB46 M26 IO/DIFFIO_RX12n(B2,V3B2)
J3 EXDB47 M27 IO/DIFFIO_RX11p(B2,V3B2)
J4 EXDB58 N1 IO/DIFFIO_RX32p(B5,V4B5)
J9 EXDB59 N3 IO/DIFFIO_TX29p(B5,V4B5)
EXDB7 N4 IO/DIFFIO_TX29n(B5,V4B5)
EXDB4 N5 IO/DIFFIO_TX40n(B6,V4B6)
EXDB4 N6 IO/DIFFIO_TX40p(B6,V4B6)
J18 EXDB38 N7 IO/DIFFIO_TX31n(B5,V4B5)
J25 EXDB38 N7 IO/DIFFIO_TX31p(B5,V4B5)
J26 EXDB78 N8 IO/DIFFIO_TX30p(B5,V4B5)
J27 EXDB78 N9 IO/DIFFIO_TX32p(B5,V4B5)
J28 EXDB79 N10 IO/DIFFIO_TX32n(B5,V4B5)
K1 EXDB50 N28 IO/DIFFIO_RX11n(B2,V3B2)
K2 EXDB51 N28 IO/DIFFIO_RX11p(B2,V3B2)
K3 EXDB48 N28 IO/DIFFIO_RX11n(B2,V3B2)
K4 N28 IO/DIFFIO_RX11p(B2,V3B2)
K7 N28 IO/DIFFIO_RX11n(B2,V3B2)
K8 N28 IO/DIFFIO_RX11p(B2,V3B2)
K19 LED-OE4 N28 IO/DIFFIO_RX11n(B2,V3B2)
K21 LED-OE4 N28 IO/DIFFIO_RX11p(B2,V3B2)
K22 N28 IO/DIFFIO_RX11n(B2,V3B2)
K25 N28 IO/DIFFIO_RX11p(B2,V3B2)
K26 EXDB76 N28 IO/DIFFIO_RX15p(B2,V3B2)
K27 EXDB77 N28 IO/DIFFIO_RX15n(B2,V3B2)
K28 EXDB77 N28 IO/DIFFIO_RX15p(B2,V3B2)

EP1S10-FBGA780

DEVICE1C

T1 EXDB63 EXDB27 W1 IO/DIFFIO_RX37p(B6,V3B6)
T3 EXDB60 EXDB24 W2 IO/DIFFIO_RX37n(B6,V3B6)
T4 EXDB62 EXDB26 W3 IO/DIFFIO_RX38p(B6,V4B6)
T5 EXDB9 EXDB16 W4 IO/DIFFIO_RX38n(B6,V4B6)
T6 EXDB6 EXDB19 W5 IO/DIFFIO_TX43n(B6,V4B6)
T7 EXDB8 EXDB18 W6 IO/DIFFIO_TX43p(B6,V4B6)
T8 W18 IO(B8,V4B8)
T9 W19 IO/RUP8(B8,V4B8)
T10 EXDB65 W23 IO/DIFFIO_TX0p(B1,V3B1)
T19 EXDB64 W24 IO/DIFFIO_TX0n(B1,V3B1)
T20 EXDB67 W25 IO/DIFFIO_RX5n(B1,V3B1)
T21 EXDB66 W26 IO/DIFFIO_RX5p(B1,V3B1)
T22 EXDB74 EXDB69 W27 IO/DIFFIO_RX6n(B1,V4B1)
T23 EXDB34 EXDB68 W28 IO/DIFFIO_RX6p(B1,V4B1)
T24 EXDB35 EXDB28 Y1 IO/DIFFIO_RX39p(B6,V4B6)
T25 EXDB32 EXDB29 Y2 IO/DIFFIO_RX39n(B6,V4B6)
T26 EXDB30 EXDB31 Y3 IO/DIFFIO_RX40p(B6,V4B6)
T26 EXDB30 EXDB30 Y4 IO/DIFFIO_RX40n(B6,V4B6)
U2 EXDB21 EXDB50 Y9 IO(B7,V5B7)
U3 EXDB20 EXDB50 Y11 IO(B7,V4B7)
U4 EXDB10 EXDB50 Y19 IO/RDN8(B8,V4B8)
U5 EXDB13 DB50 Y26 IO/DIFFIO_RX3n(B1,V3B1)
U6 EXDB12 DB63 Y26 IO/DIFFIO_RX3p(B1,V3B1)
U7 EXDB11 DB61 Y27 IO/DIFFIO_RX4n(B1,V3B1)
U8 DB58 Y28 IO/DIFFIO_RX4p(B1,V3B1)
U9 DB23 AA1 IO/DIFFIO_RX41p(B6,V4B6)
U10 DB20 AA2 IO/DIFFIO_RX41n(B6,V4B6)
U11 DB19 AA3 IO/DIFFIO_RX42p/RDN6(B6,V4B6)
U12 DB18 AA4 IO/DIFFIO_RX42p/RUP6(B6,V4B6)
U13 EXDB71 DB48 AA25 IO/DIFFIO_RX1p/RUP1(B1,V3B1)
U14 EXDB72 DB62 AA26 IO/DIFFIO_RX1n/RDN1(B1,V3B1)
U14 EXDB75 DB60 AA27 IO/DIFFIO_RX2n(B1,V3B1)
U14 EXDB75 DB57 AA28 IO/DIFFIO_RX2p(B1,V3B1)
V1 EXDB22 DB21 AB1 IO/DIFFIO_RX43p(B6,V4B6)
V2 EXDB23 DB21 AB2 IO/DIFFIO_RX43n(B6,V4B6)
V3 EXDB25 DB29 AB7 IO(B7,V4B7)
V4 EXDB15 DB59 AB11 IO/RUP7(B7,V5B7)
V5 EXDB14 DB59 AB18 IO(B8,V5B8)
V6 EXDB17 DB56 AB27 IO/DIFFIO_RX0n(B1,V3B1)
V7 DB25 AC10 IO/DIFFIO_RX0p(B1,V3B1)
V8 DB31 AD6 IO/RDN7(B7,V5B7)
V9 DB26 AD8 IO/DQ1B3(B7,V4B7)
V10 DB24 AD10 IO/DQ2B2(B7,V4B7)
V11 DB55 AD18 IO/DQ3B0(B7,V5B7)
V12 DB53 AD19 IO/DQ6B2(B8,V4B8)
V13 EXDB33 DB51 AD21 IO/DQ6B6(B8,V4B8)
V14 EXDB73 DB49 AD23 IO/DQ7B7(B8,V5B8)
V14 EXDB73 DB49 AD23 IO/DQ8B6(B8,V5B8)

EP1S10-FBGA780

PCIIRST# <<<
PCIAD[31..0] <<<
C/BE#[3:0] <<<
INT# <<<
GNT# <<<
IDSEL <<<
FRAME# <<<
TRDY# <<<
STOP# <<<
PAR <<<
DEVSEL# <<<
IRDY# <<<
SERR# <<<
PERR# <<<
REQ# <<<

Table with columns: DESIGNED, DRAWN, CHECKED, APPROVED, DATE, MODEL, TITLE, DRAW No., REV. Content includes: {designnd}, {drawn}, {chekd}, {approved}, 2002.8.9, EV-Stratix, ALTERA Stratix FF780, SK-Electronics CO.,LTD., 2.4

Table with columns: SYM, REVISION, DATE, REVISED, APPROVED. Content includes: 3, 4, 5, 6, 7, 8, 9, 10, 11, 12, 13, 14, 15, 16, 17, 18, 19, 20, 21, 22, 23, 24, 25, 26, 27, 28, 29, 30, 31, 32, 33, 34, 35, 36, 37, 38, 39, 40, 41, 42, 43, 44, 45, 46, 47, 48, 49, 50, 51, 52, 53, 54, 55, 56, 57, 58, 59, 60, 61, 62, 63, 64, 65, 66, 67, 68, 69, 70, 71, 72, 73, 74, 75, 76, 77, 78, 79, 80, 81, 82, 83, 84, 85, 86, 87, 88, 89, 90, 91, 92, 93, 94, 95, 96, 97, 98, 99, 100

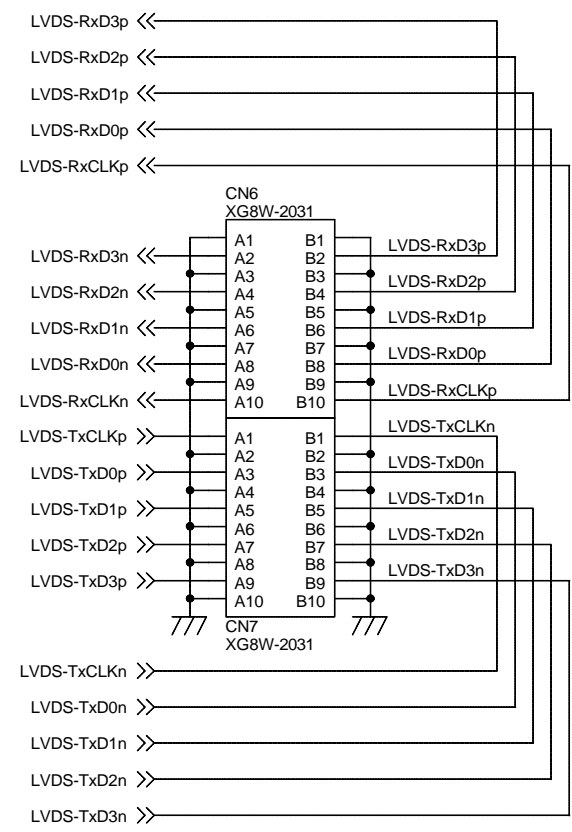
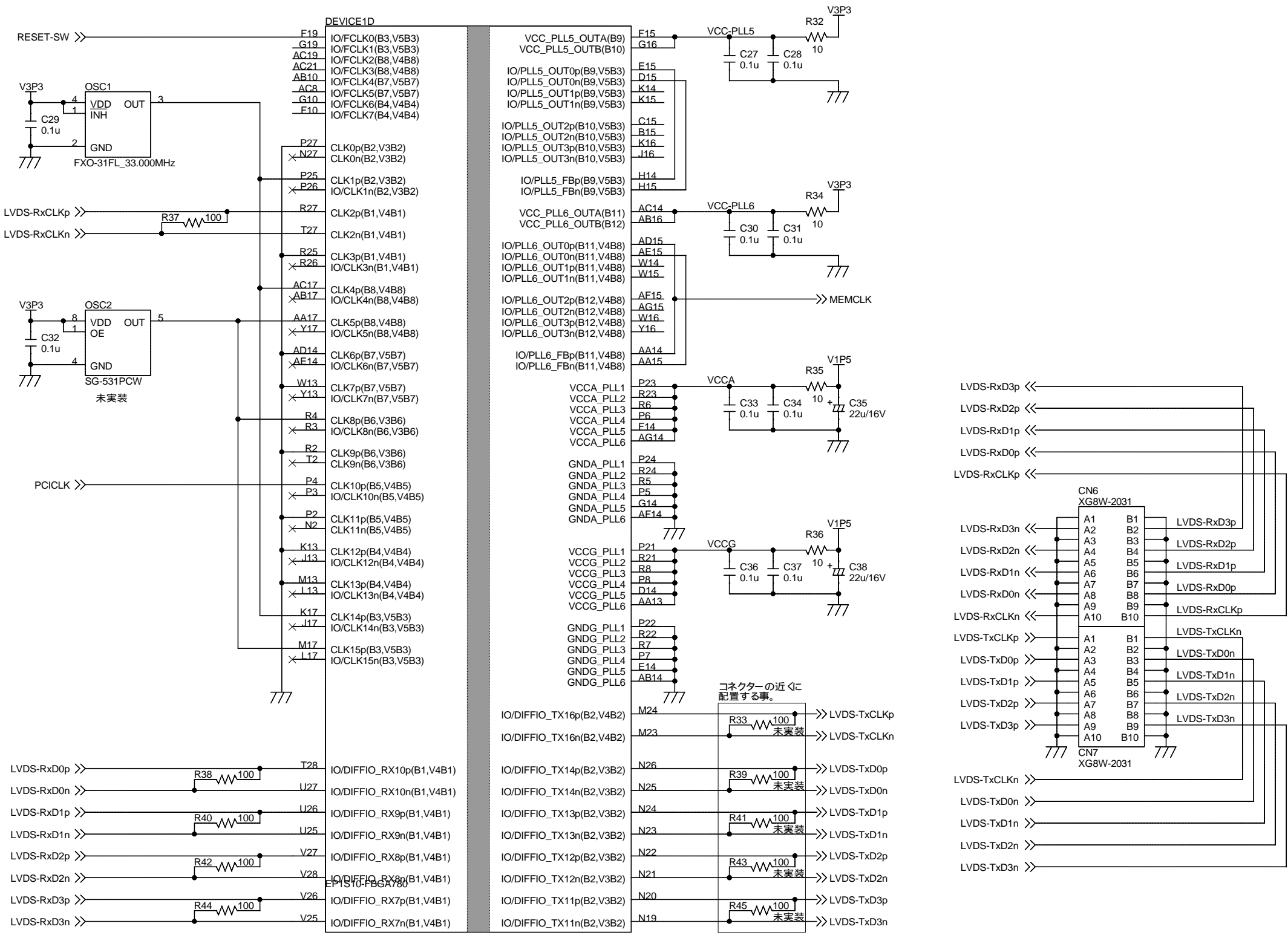

DESIGNED	{designd}	TITLE	
DRAWN	{drawn}	LVDS-I/O Tx/Rx/CLK	
CHECKED	{chekd}	Size A3	
APPROVED	{approved}	(6 / 8)	
DATE	2003.1.14	MODEL	EV-Stratix
SYMBOL	REVISION	DATE	REVISED
			APPROVED
			SK-Electronics CO.,LTD.
			2.4

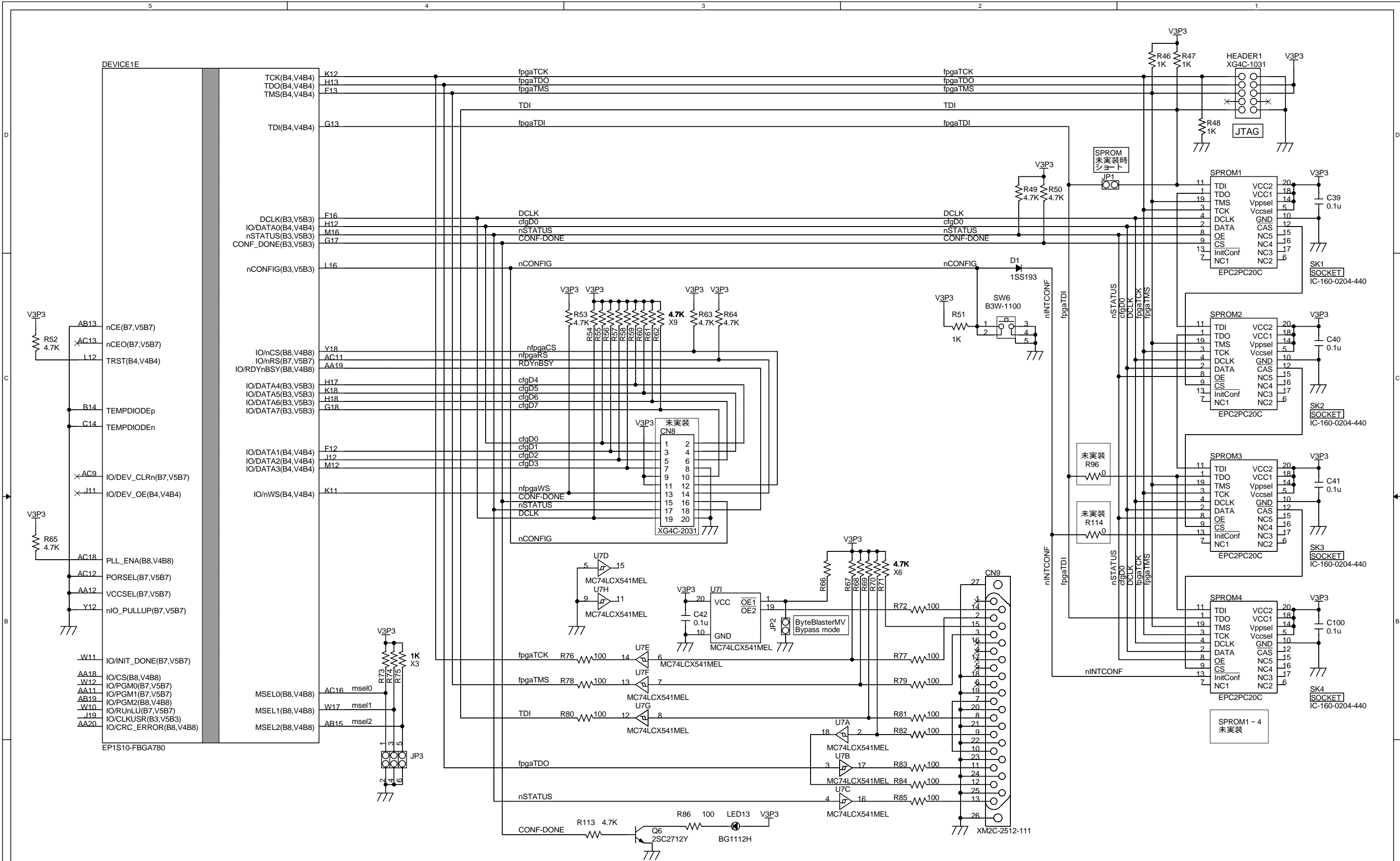

DESIGNED	{designd}	TITLE	JTAG-I/F,PS-I/F,PP-I/F
DRAWN	{drawn}		
CHECKED	{chekd}		
APPROVED	{approved}		
DATE	2002.12.13	Size A3	(7 / 8)
MODEL	EV-Stratix	DRAW No.	(doc)
REVISION		SK-Electronics CO.,LTD.	
SYM		REV	2.4

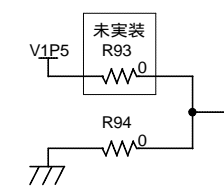
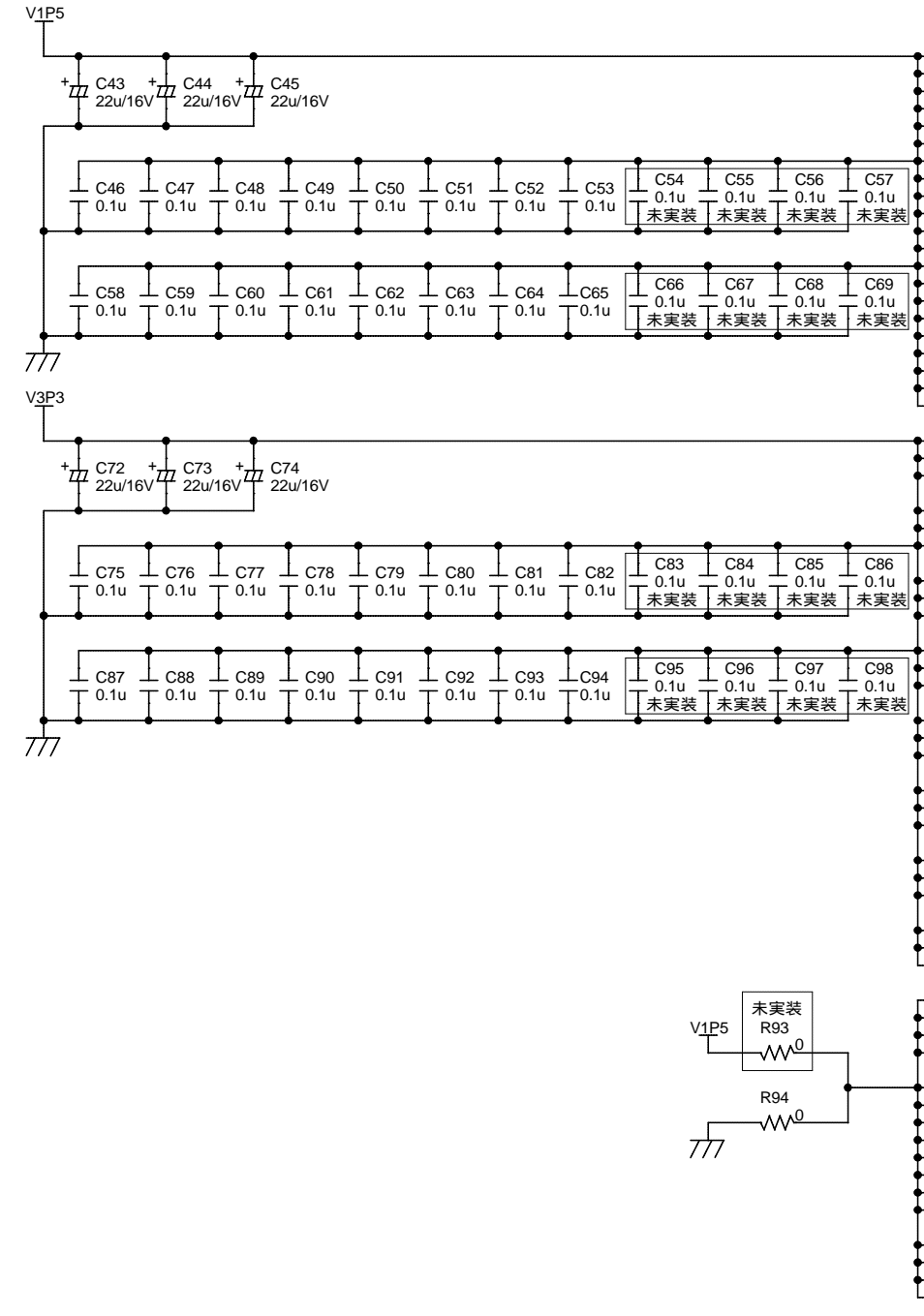
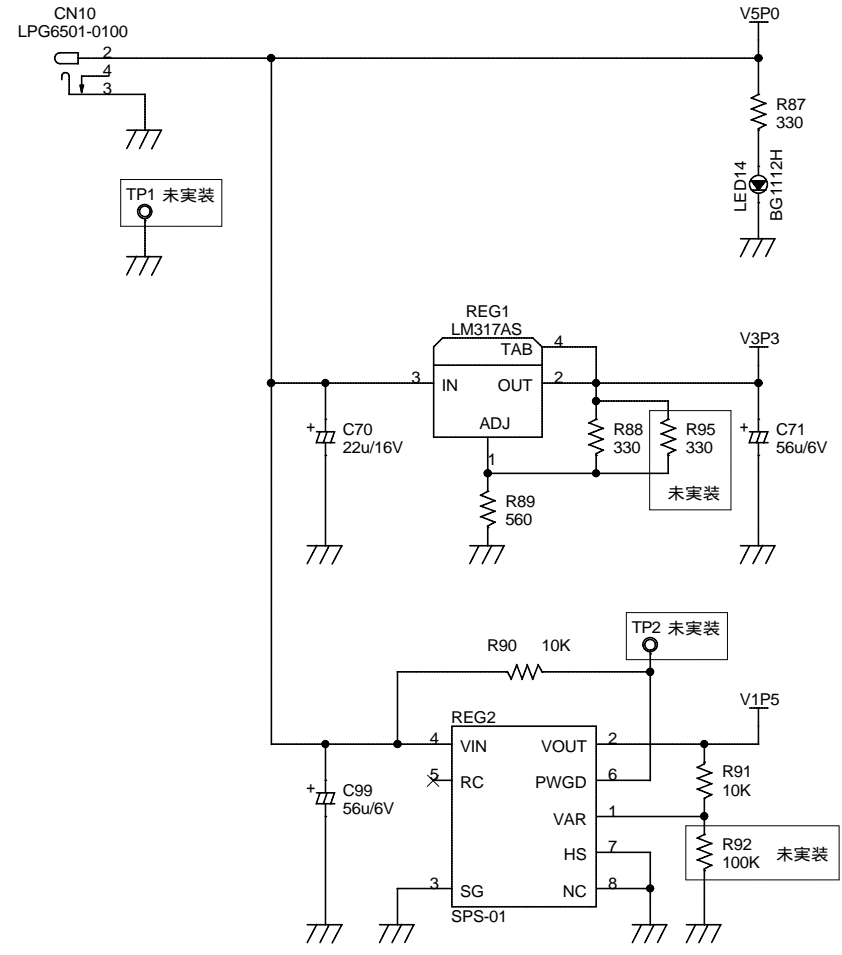

Pin	Signal	Device1F	Device1G
M14	VCCINT	NC8	C2
N11	VCCINT	NC9	C12
N13	VCCINT	NC10	C13
N15	VCCINT	NC11	C16
N17	VCCINT	NC12	C17
P12	VCCINT	NC13	C28
P14	VCCINT	NC14	D1
P16	VCCINT	NC15	D2
R13	VCCINT	NC16	D3
R15	VCCINT	NC17	D4
R17	VCCINT	NC18	D12
T12	VCCINT	NC19	D13
T14	VCCINT	NC20	D16
T16	VCCINT	NC21	D17
T18	VCCINT	NC22	D25
U11	VCCINT	NC23	D26
U13	VCCINT	NC24	D27
U15	VCCINT	NC25	D28
U17	VCCINT	NC26	F1
V12	VCCINT	NC27	F2
V16	VCCINT	NC28	F3
R20	VCCIO1	NC29	F4
U28	VCCIO1	NC30	F5
AG28	VCCIO1	NC31	F11
B28	VCCIO2	NC32	F12
M28	VCCIO2	NC33	F13
P20	VCCIO2	NC34	F16
A17	VCCIO3	NC35	F25
A27	VCCIO3	NC36	F26
J15	VCCIO3	NC37	F27
A2	VCCIO4	NC38	F28
A12	VCCIO4	NC39	G3
J14	VCCIO4	NC40	G4
B1	VCCIO5	NC41	G5
M1	VCCIO5	NC42	G6
P9	VCCIO5	NC43	G8
R9	VCCIO6	NC44	G9
AG1	VCCIO6	NC45	G12
Y14	VCCIO7	NC46	G21
AH2	VCCIO7	NC47	G22
AH12	VCCIO7	NC48	G23
Y15	VCCIO8	NC49	G24
AH17	VCCIO8	NC50	G15
AH27	VCCIO8	NC51	H16
W20	VREF3B1(B1,V3B1)	NC52	L14
K20	VREF3B2(B2,V3B2)	NC53	L15
K9	VREF3B5(B5,V3B5)	NC54	L15
W9	VREF3B6(B6,V3B6)	NC55	M15
R19	VREF4B1(B1,V4B1)	NC56	N12
E24	VREF4B2(B2,V4B2)	NC57	N14
E20	VREF4B3(B3,V4B3)	NC58	N16
F9	VREF4B4(B4,V4B4)	NC59	N18
P10	VREF4B5(B5,V4B5)	NC60	N18
AE3	VREF4B6(B6,V4B6)	NC61	P1
AD9	VREF4B7(B7,V4B7)	NC62	P11
AD20	VREF4B8(B8,V4B8)	NC63	P13
F18	VREF5B3(B3,V5B3)	NC64	P15
F7	VREF5B4(B4,V5B4)	NC65	P17
AD11	VREF5B7(B7,V5B7)	NC66	P18
AD22	VREF5B8(B8,V5B8)	NC67	P18
A13	NC1	NC68	R1
A16	NC2	NC69	R11
B12	NC3	NC70	R12
B13	NC4	NC71	R14
B16	NC5	NC72	R16
B17	NC6	NC73	R18
C1	NC7	NC74	R28
		NC75	T11
		NC76	T13
		NC77	T15
		NC78	T17
		NC79	T17
		NC80	U12
		NC81	U14
		NC82	U16
		NC83	U18
		NC84	V13
		NC85	V13
		NC86	V14
		NC87	V15
		NC88	V15
		NC89	V17
		NC90	AA16
		NC91	AC15
		NC92	AF3
		NC93	AF26
		NC94	AG2
		NC95	AG27
		NC96	AH14
		NC97	AH15
		NC98	AH15
		NC99	AH15
		NC100	AH15
		NC101	AH15
		NC102	AH15
		NC103	AH15
		NC104	AH15
		NC105	AH15
		NC106	AH15
		NC107	AH15
		NC108	AH15
		NC109	AH15
		NC110	AH15
		NC111	AH15
		NC112	AH15
		NC113	AH15
		NC114	AH15
		NC115	AH15

DESIGNED	{designd}	TITLE Power Unit 5.0V/3.3V/1.5V			
DRAWN	{drawn}				
CHECKED	{chekd}				
APPROVED	{approved}	Size A3 (8 / 8)			
DATE	2002.11.27				
MODEL	EV-Stratix	DRAW No. (doc)			
REVISION	DATE	REVISED	APPROVED	SK-Electronics CO.,LTD.	2.4